

DVI over CAT5 Transmitter - ID# 750
DVI over CAT5 100m Receiver Box - ID# 752



Operation Manual

Introduction

DVI transmitter and receiver over CAT 5 is a pair of extender for DVI signal - up to 100 meters long. Not only can this device transfer the HD image signal but also the analog/digital audio signal with coaxial and L/R audio port. This extender is perfect for extending high resolution digital display with crystal clear images over low cost CAT5 solution

Applications

- For long distance DVI source display in a separate room or class.
- For long distance digital and analog sounds transferring up to 100M long.
- Any PC source equipment with output DVI connector.

System Requirements

PC/DVI source with DVI output connector, DVI to DVI cable(s), CAT 5 cable(s) and DVI display monitor.

Features

- Compliant with HDMI 1.2, and DVI 1.0 specifications.
- Support Equalizer, and Gain adjustment.
- Supports high definition input up to 1080P/WUXGA, output resolution follows input.
- Easy to install and simple to operate.
- Connect CAT 5 back to DVI without signal loss after 100 meter's transmission.
- Not compatible with HDCP Source.
- Build-in EDID at transmitter.
- Support both external Coaxial and Stereo Sound.

Transmitter's Front Panel

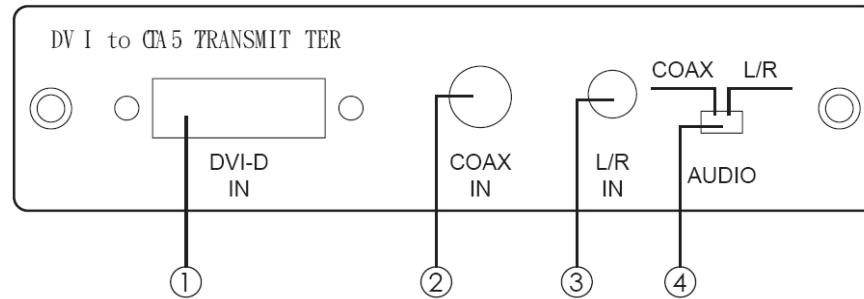

- ① **DVI-D IN** – Plug from DVI/HDMI source equipment's video output with DVI in cable.
- ② **COAX IN** – Plug from DVI/HDMI source equipment's audio output with coaxial cable.
- ③ **L/R IN** – Plug from DVI/HDMI source equipment's audio output with L/R phone jack cable.
- ④ **AUDIO switch** – Switch your audio source by COAX in or L/R in.

Note: 1. When Coax-in's audio format is bitstream (AC3, DTS and....etc.) Coax-out will perform the some format, but L/R out will perform no sound therefore, audio source format will need to be change to LPCM in order to get L/R out to perform.
 2. When inputing HDMI Source with audio signal throug HDMI to DVI-D adaptor and output DVI-D with DVI-D to HDMI adaptor, the audio will remain with HDMI instead of COAX or L/R IN.

Transmitter's Rear Panel

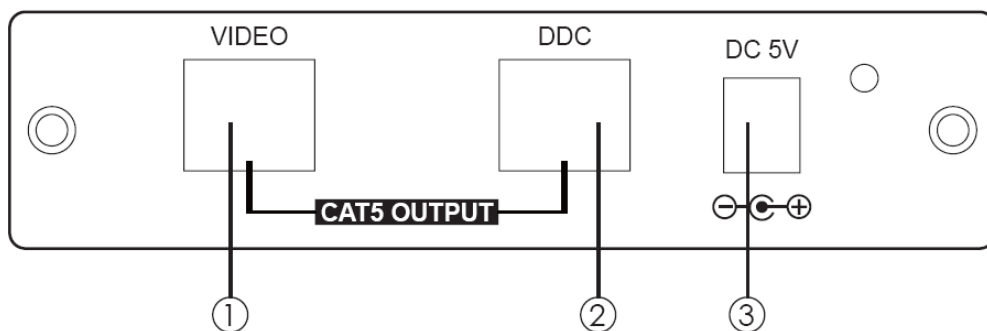

- ① **VIDEO CAT5 OUTPUT**-connect the VIDEO output to the VIDEO input of receiver with CAT-5/CAT-5E cable.
 - ② **Power Jack** – Connect with 5V / 2.6A power adaptor with power supply.
- Note:** 1. When using video connector only for signal transmit with transmitter and receiver, the DVI-D output signal will have auto HDCP protection.
 2. When using both video and DDC connector for signal transmit

with transmitter and receiver, the DVI-D output signal's HDCP protection will depend on input signal.

- Input with HDCP protection, Output with HDCP protection.
- Input without HDCP protection, Output without HDCP protection.

Receiver's Front Panel

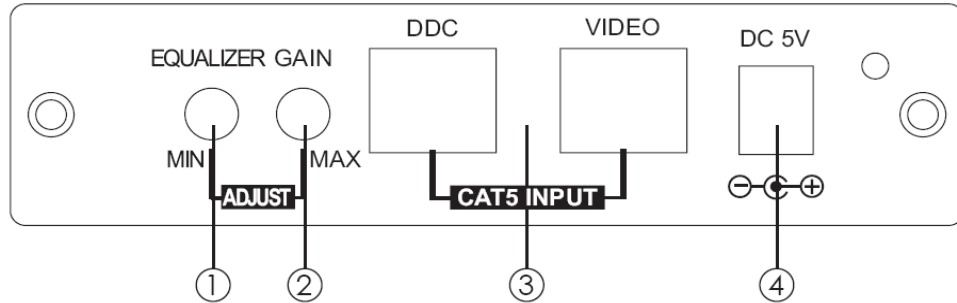

- ① **EQUALIZER** – Use this switch to adjust Sharpness/Peak over long distance by turning right or left.
- ② **GAIN** – Use this switch to adjust Brightness/Contrast by turning right or left.
- ③ **VIDEO CAT 5 INPUT** – Connect the VIDEO input to the Video output of the transmitter with CAT-5/CAT-5E cable.
(Suggest using solid UTP CAT5 cable for better performance)
- ④ **Power Jack** – Connect with 5V / 2.6A power adaptor with power supply.

Receiver's Rear Panel

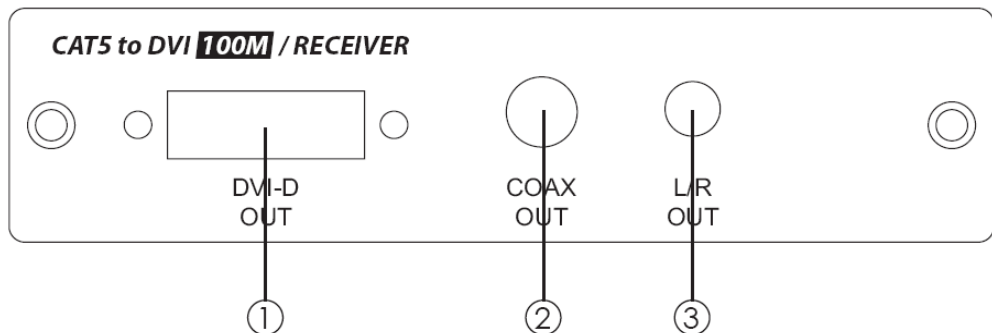

- ① **DVI-D OUT** – Connect to DVI display monitor with DVI cable.
- ② **COAX OUT** – Connect to audio amplifier or audio equipment's input with coaxial cable.
- ③ **L/R OUT** – Connect to audio equipment's input with 3.5mm phone jack.

Connection and Installation

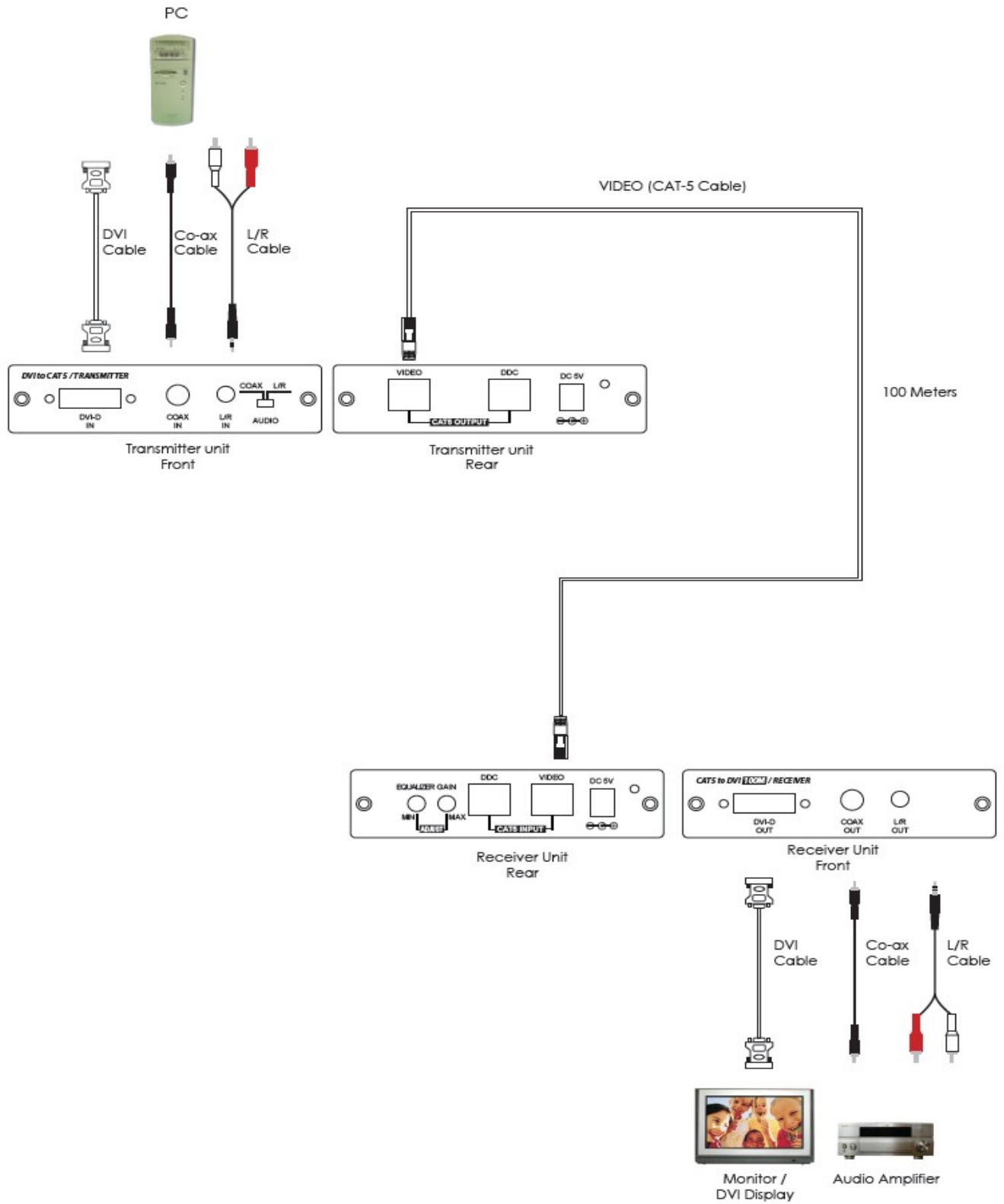

Specifications

| | |
|--------------------------------|--|
| Transmitter Input port | 1 x DVI-I female port (Accept DVI-D signal only) 1 x Coaxial 1 x L/R Audio |
| Transmitter Output port | 2 x CAT5 RJ 45 8pin |
| Receiver Input port | 2 x CAT5 RJ 45 8pin |
| Receiver Output port | 1 x DVI-I female port (Output DVI-D Signal only) 1 x Coaxial 1 x L/R Audio |
| Resolution | HD- 480i/p 60, 576p 50, 720P 50/60, 1080i 50/60Hz, 1080p 50/60Hz PC- 640 x 480=VGA72, VGA75, VGA85 800 x 600=SVGA56, SVGA60, SVGA72, SVGA75, VGA85 1024 x 768=XGA60, XGA70, XGA75, XGA85 1280 x 1024=SXGA60, SXGA75, SXGA85 1600 x 1200=UXGA60 1920 x 1200=Reduced blanking WUXGA |
| Power Supply | 5V / 2.6A DC power supply |
| Dimensions (mm) | 125 x 130 x 30 / each |
| Weight (g) | 700 /each |
| Material | Aluminum |
| Color | Silver |
| Power Consumption | Transmitter 7W Receiver 6W |