

***DVI Digital scaler with
ultra high bandwidth ID#442***



Operation Manual

Introduction

Congratulations on your purchase of the DVI Digital scaler with ultra high bandwidth.

Please read this to become familiar with the DVI Digital scaler with ultra high bandwidth and keep the manual for possible reference in the future.

The DVI Digital scaler with ultra high bandwidth is designed to convert PC, SD, HD and DVI to digital

DVI at a variety of HDTV and PC resolutions. It handles input and output signal at 205 MHZ ultra high bandwidth. The DVI Digital scaler with ultra high bandwidth has many great features to enhance video performance and is ideal for use in professional large screen presentation.

Features

- 1.** DVI Digital scaler with ultra high bandwidth is a high bandwidth and professional PC/Component/DVI to DVI Scaler that accepts PC RGB (up to UXGA), HD Component(480i up to 1080p) and DVI (up to WUXGA) and scale them up to DVI-I output (1080p/WUXGA).
- 2.** The input to the DVI Digital scaler with ultra high bandwidth is analog PC or HDTV signal in the format of either RGBHV, YPbPr, (YCbCr) or digital DVI.
- 3.** The output of the DVI Digital scaler with ultra high bandwidth is digital DVI plus analog PC/HD with selectable output resolution from 480i to 1080p and VGA to WUXGA.
- 4.** The input resolution is automatically detected while the output resolution and refresh rate can be selected through OSD menu or front panel push buttons.
- 5.** Native output resolution ensures most optimal display resolution on your screen. When "Native" is selected as the output resolution, the DVI Digital scaler with ultra high bandwidth will automatically detect the native resolution of the display and send out the most optimal pixel timing to match TV's final display resolution.
- 6.** Output picture adjustment on brightness, contrast, color, RGB level, and H-V position.
- 7.** The DVI input is HDCP compliant which means if input is HDCP encrypted then DVI output is also HDCP encrypted. In this case the PC analog output will be turned off.
- 8.** Includes advanced features such as Noise Reduction and overscan/underscan adjustment.

Operating Functions and Controls Front Panel

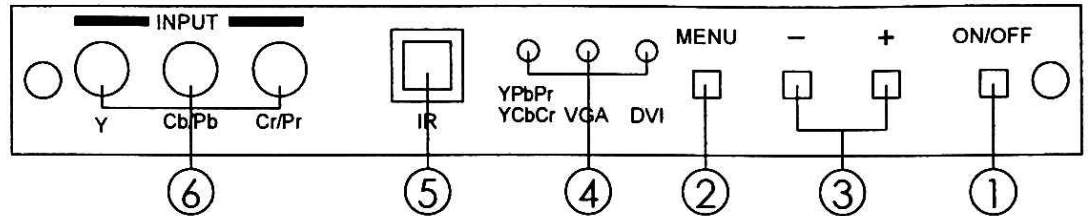

1. Power: Press the button to turn ON or turn OFF (standby) the power of the unit.

2. Menu/Enter: This button serves two purposes.

- Press the button to bring up OSD main menu as shown in the "OSD Operation".
- To act as a "Enter" key to enter sub menu or to adjust setting value of the selected parameter.

3. +/- button:

The buttons provide 3 functions:

a. Input select ("+"): Press the "+" button repeatedly to select your desired input source. The input sources are toggled through in the following sequence.

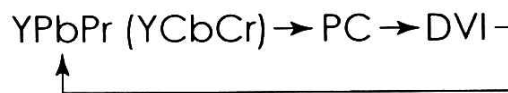

- Auto Tune** Press the "-" button to carry out picture auto adjust for analog inputs (component or PC). the DVI Digital scaler with ultra high bandwidth will fine tune the position (centering) and color of the output picture.
- When in the OSD menu mode: Press the +/- button to move up or down the highlight bar to your desired parameter. Or once a parameter is selected with MENU/Enter button, press the button to adjust setting value of your selected parameter.

4. Input LED Indicators: When one of the LED illuminates its corresponding source is being selected as input.

5. **IR Sensor:** Infrared remote control sensor.

6. **Component Input:** Connects this input connector to the Component output connector of your source equipment using the enclosed 3RCA to 3RCA cable. the DVI Digital scaler with ultra high bandwidth accepts both interlaced component input (480i, 576i) and de-interlaced progressive input (480p, 576p... 1080p).

The input range is 480i, 570i-1080i, 1080p.

Rear Panel

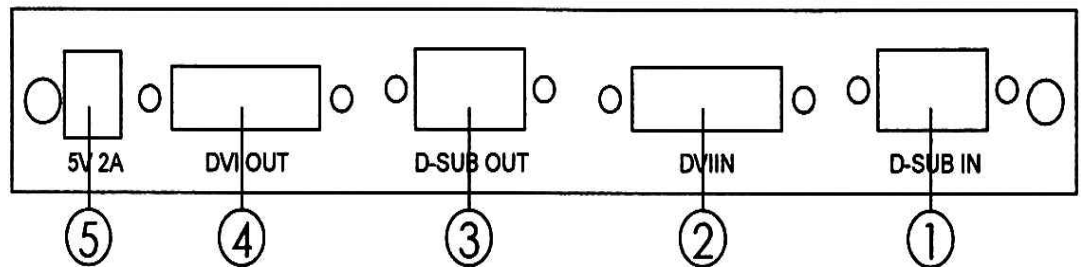

1. **PC input:** Connects this PC input connector to the VGA output of your PC. The acceptable PC resolutions range from VGA-WUXGA.

2. **DVI input:** Connects this DVI input connector to the DVI output connector of your DVI source equipment. The DVI input should be digital DVI only and should not include analog RGB signal.

The use of DVI-I connector is to ensure both DVI-I and DVI-D male connector of the DVI cable can fit into this input connector. The digital DVI input resolution can range from 480i-1080p, or VGA-WUXGA.

3. **PC-D sub out:** The connector for scaled analog RGB output. Connect this output port to the analog PC RGB input of your monitor, or connect it to the RGBHV input of your HD display using D-sub to 5 BNC adapter cable. (not included in the package)

Note: When input is a HDCP encrypted DVI signal this analog output will be turned off.

4. **DVI output:** Scaled digital DVI output. Connect this output to the DVI input or HDMI input of your Digital display.

Note: When input is a HDCP encrypted DVI signal the DVI output is also HDCP encrypted. The monitor/display that connected to this output also need to be HDCP compliant in order to get a nice and clean

picture. A non-HDCP compliant display can only display non-HDCP signal and picture will become noise when input is a HDCP-encrypted signal.

5. Power jack: Connect to the 5V 2A DC power adapter.

Remote Control and functions

1. Power: Press the button once to power on the DVI Digital scaler with ultra high bandwidth. Press again to enter standby mode.

2. Input: Press the button repeatedly to toggle through various input sources as follows.



3. HD input: Press the button to select component input.

4. PC input: Press the button to select PC input.

5. HDMI/DVI input: Press the button to select DVI (or HDMI) input.

6. Output resolution:

Select buttons: Press any one of the button to directly select output resolution.

For other output resolutions that are not covered by these buttons please enter Menu/Output page to select them.

7. MENU: Press the button to bring up OSD main menu page.

8. Exit: Press the button to exit from a sub menu or main menu.

9. Up/Down/Left/Right: Press the Up/Down button to move the highlight bar to your desired parameter during the OSD operation.

Press the Left/Right button to increase/decrease the setting value of a selected parameter.

10. OK (Enter): Press the button to confirm your selection.

11. Reset: Press the button to reset the unit's firmware setting to the factory default value.

12. Auto Adjust: Press the button to optimize the position of the picture (picture centering) on the screen.

Remote Control
(cont)

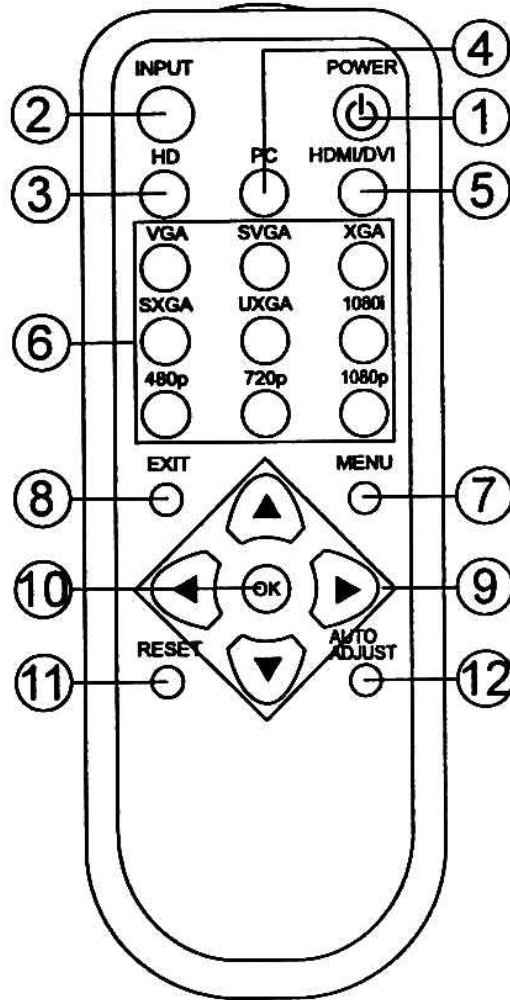

Installation Input Connection

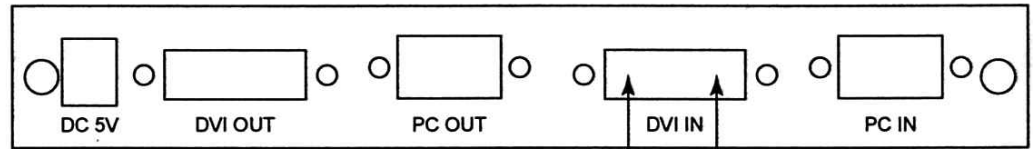
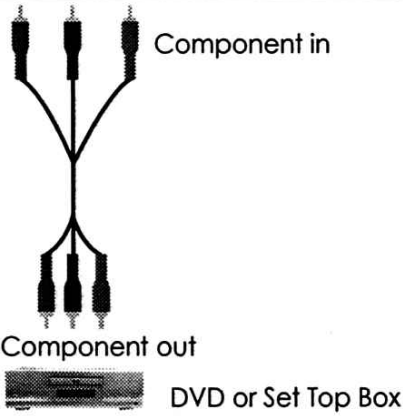
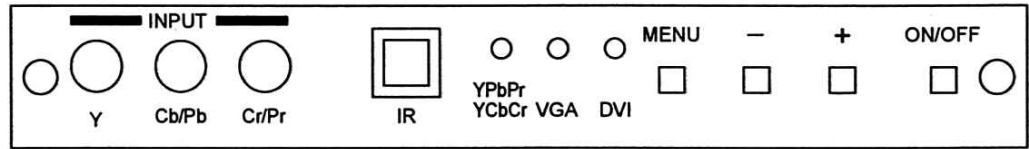

HDMI to DVI connector adaptor

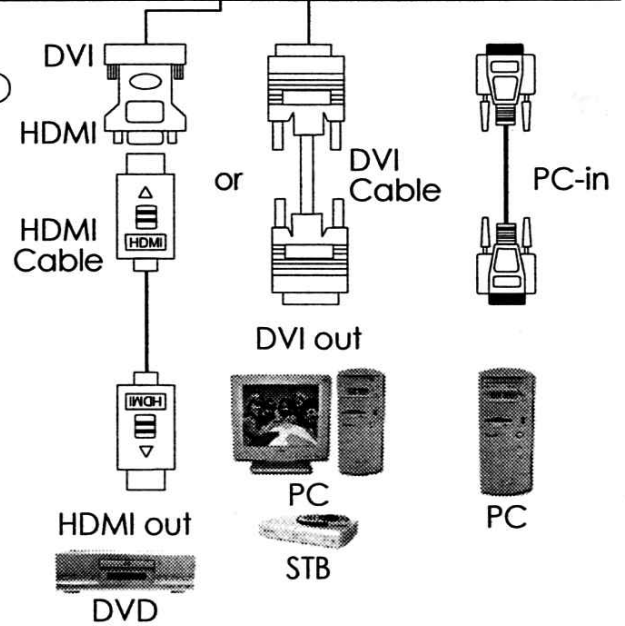

The DVI Digital scaler with ultra high bandwidth accepts component, PC and DVI inputs. The formats supported by these inputs are as follows:

Component Input

YPbPr	480p@50/60Hz
	576p@50Hz
	720p@50/60Hz
	1080i@50/60Hz
	1080p@50/60Hz
YCbCr	480i@60Hz
	576i@50Hz

PC Input:	RGBHV	VGA/SVGA/XGA/SXGA/UXGA/WXGA/WSXGA/WUXGA VGA@(60/72/75/85)/SVGA@(56/60/72/75/85)/ XGA@(60/70/75/85)/SXGA@(60/75/85)/UXGA@60/ WXGA@60(1280x800)/WSXGA@60(1680x1050)/ WUXGA@60(1920x1200)/1360x768
DVI Input:	Digital	VGA@(60/72/75/85)/SVGA@(56/60/72/75/85)/ XGA@(60/70/75/85)/SXGA@(60/75/85)/UXGA@60/ WXGA@60(1280x800)/WSXGA@60(1680x1050)/ WUXGA@60(1920x1200)/1360x768

- When connecting to a PC source use a 15-pin D-sub cable to connect the output of a PC to the D-Sub input connector of the DVI Digital scaler with ultra high bandwidth.
- When connecting to a component source (either SD or HD resolution) use a 3RCA to 3RCA cable to connect the YPbPr or YCbCr output of a DVD or Set Top Box to the Y-Cb/Pb-Cr/Pr input connector of the DVI Digital scaler with ultra high bandwidth.

– When connecting to a DVI source, use a DVI-I or DVI-D cable to connect the DVI output of a PC or DVD to the DVI input connector of the DVI Digital scaler with ultra high bandwidth. - When connecting to a HDMI source, use a HDMI cable to connect to the HDMI output of a HDMI source, such as DVD or STB, on the one end.

And use a HDMI to DVI connector adapter to connect to the other end of the HDMI cable. The DVI connector of the adapter is then connect to the DVI input of the DVI Digital scaler with ultra high bandwidth.

The DVI Digital scaler with ultra high bandwidth can automatically detect the input resolution of all three inputs. To switch from one input source to another just press the input button on the front panel ("+") or on the remote control.

Output Connection

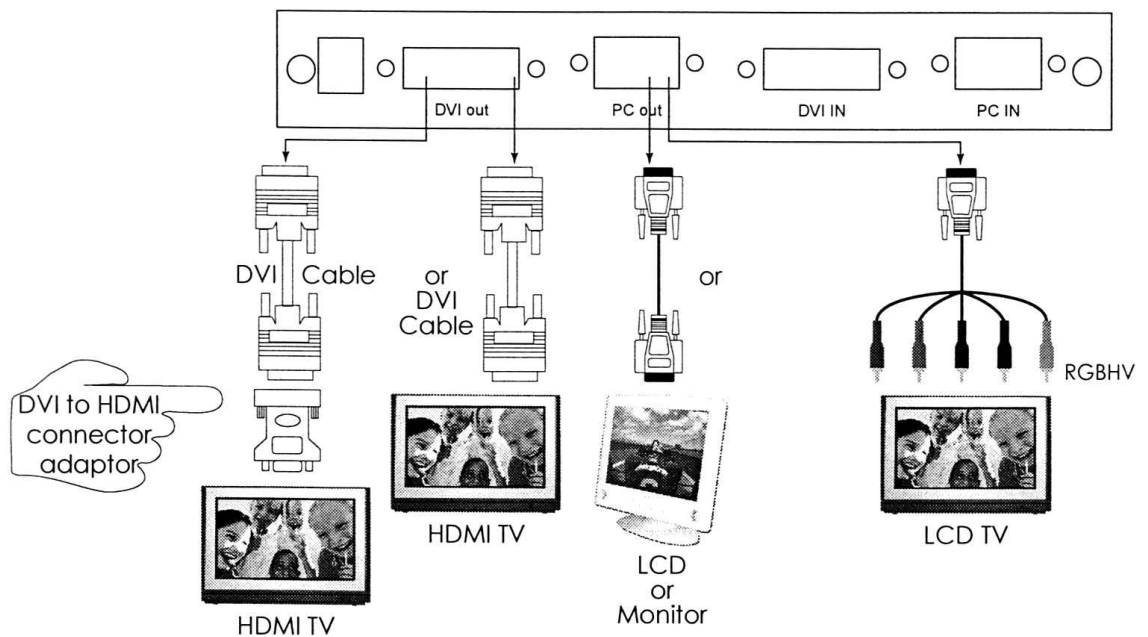

The DVI Digital scaler with ultra high bandwidth can output a variety of PC, SD and HD resolutions in both digital and analog format simultaneously.

The digital output is available from the DVI output connector while the analog output is available from the PC D-sub output connector.

The digital output supports the following resolutions, all in RGB format. HD: 480i, 480p, 576i, 576p, 720p@50/60, 1080i@50/60, 1080p@50/60

PC: VGA @60/ SVGA@60/XGA@60/ SXGA@60/ WXGA@60/ WSXGA@60/ UXGA@60/ WUXGA@60

The analog output supports the following resolutions (all in RGB format). 480i/480p/576i/576p/720p@(50/60) /1080i@(50/60) / 1080p@(50/60) / VGA@60/ SVGA@60/ XGA@60/ SXGA@60/ UXGA@60/ WXGA@60/ WSXGA@60/ WUXGA@60

OSD Operation

After power on the unit, press the "menu" button will bring up the main menu as follows:

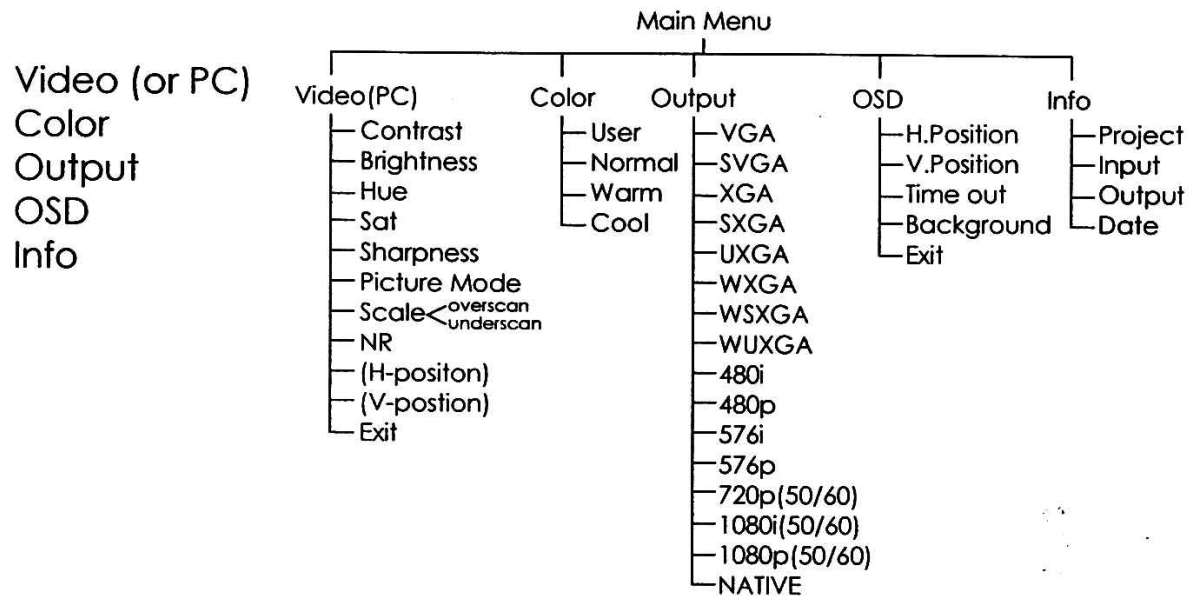

Use +, - button to move highlight bar to your desired parameter, then press MENU/ENTER to enter into sub-menu of your selected parameter.

Video (or PC): When Video is selected a sub menu as below comes up.

Contrast

Brightness

Hue

Saturation

Sharpness

Picture Mode – - User
- Standard
- Vivid
- Movie

Scale – - Underscan

- Overscan

NR - - Low

- Middle

- High

- Off

Note (PC): Available only when PC is selected as input.

To adjust picture quality, Use "+,-" to move the highlight bar to your desired adjust item, press the Menu/Enter to confirm your selection.

At this point, the selected parameter will turn red, you can then use "+,-" to increase or decrease the value of the parameter.

When adjustment is complete, press "Menu" to leave the parameter. Move the highlight bar to "Exit", then press Menu/Enter to exit.

Note: The "H-position" and "V-position" are only available when component or PC input is selected. Neither are available when the DVI input is selected.

Picture mode -there are 4 picture modes for customer to choose from.

User: Select to adjust to your favorite setting and store it.

Standard: Standard factory default setting for optimal display in a normal environment.

Vivid: High saturation picture for optimal display in a bright room.

Movie: Picture for comfortable low brightness display in a dark room.

Scale: select overscan when input source is SD or HD video to ensure no black band around screen border. Select underscan when input source is PC signal to ensure full picture content fall within screen border.

Noise Reduction: This function only works when input is analog RGB or component. It will not work for DVI input. There are four steps of Noise Reduction-Off, Low, Middle High. The Noise Reduction will remove the noise that results from analog to digital conversion and digital scaling processing.

H & V position: To adjust for best horizontal and vertical position of the picture in the screen.

Colour

User: Select to adjust to your favorite color temperature setting.

Normal: Normal color tone setting where white is pure white.

Warm: Warm color tone makes white reddish.

Cool: Cool color tone makes white bluish.

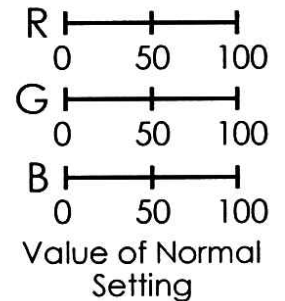

Output: The DVI Digital scaler with ultra high bandwidth can output a wide variety of PC and HD resolutions as follows.

HDMI 1.2 Compliant Input format (Up to 165MHz)

Resolution	INPUT		
	Component	D-SUB	DVI/HDMI
480i/576i	✓		*
480p/576p	✓	✓	✓
720p@[60/50]	✓	✓	✓
1080i@[60/50]	✓		✓
1080p@[60/50]	✓	✓	✓
VGA@[60/72/75/85]		✓	✓
SVGA@[56/60/72/75/85]		✓	✓
XGA@[60/70/75/85]		✓	✓
SXGA@[60/75/85]		✓	✓
UXGA@60		✓	✓
WXGA@60[1280X800]		✓	✓
WSXGA@60[1680X1050]		✓	✓
WUXGA@60[1920X1200]		✓	✓

* 480i 30x2 / 576i 25x2

Output format (Up to 165MHz)

Resolution	OUTPUT	
	D-SUB	DVI/HDMI
480i/576i	✓	*
480p/576p	✓	✓
720p@[60/50]	✓	✓
1080i@[60/50]	✓	✓
1080p@[60/50]	✓	✓
VGA@[60/72/75/85]	V(@60)	V(@60)
SVGA@[56/60/72/75/85]	V(@60)	V(@60)
XGA@[60/70/75/85]	V(@60)	V(@60)
SXGA@[60/75/85]	V(@60)	V(@60)
UXGA@60		V(@60)
WXGA@60[1280X800]	✓	✓
WSXGA@60[1680X1050]		✓
WUXGA@60[1920X1200]		✓

* 480i 30x2 / 576i 25x2

Native: When it is selected, the DVI Digital scaler with ultra high bandwidth will automatically adjust its output timing to match the native timing of the display.

OSD Adjust:

H.Position: Adjust the horizontal position of the OSD graphic.

V.Position: Adjust the vertical position of the OSD graphic.

Time out: Set a predetermined time to turn off OSD menu on the screen.
Background: To select transparent or solid background of OSD graphic.

Information:

Project: Show product model number.

Input: Show input resolution i.e XGA.

Output: Show output resolution i.e 720p.

Date: Show date of firmware version.

Specifications

HDMI 1.2 Compliant

Input format(Up to 165MHz) for

YpbPr/YCbCr: 480i, 480p, 576i, 576p, 720p@(50/60Hz),
1080i@(50/60), 1080p@(50/60)

VGA: VGA@(60/72/75/85), SVGA@(56/60/72/75/85),
XGA@(60/70/75/85). SXGA@(60/75/85), UXGA@60,
WUXGA@60

DVI:VGA@(60/72/75/85), SVGA@(56/60/72/75/85),
XGA@(60/70/75/85). SXGA@(60/75/85), UXGA@60, WUXGA@60

Output format

VGA(Up to 165MHz):

480i, 480p, 576i, 576p, 720p@(50/60),1080i@(50/60), VGA@60,
SVGA@60, XGA@60, SXGA@60 DVI(Up to 165MHz):

480i, 480p, 576i, 576p, 720p@(50/60), 1080i@(50/60),
1080p@(50/60), VGA@60, SVGA@60, XGA@60, SXGA@60,
UXGA@60, WUXGA@60

Input connectors:

– YCbCr/YPbPr x 1 via 3 RCA jack

– PC RGB x 1 via 15 pin D-sub

– DVI x 1

Output connector:

– DVI x 1

– PC 15 pin D-sub x 1

Dimension: 180(W)x124(D)x25(H)mm Weigh: 600gs

DC 5V 2.6 Amp