

1 In 2 Out UHD 4K2K Splitter Scaler ID# 15431



Operation Manual

Introduction

The 1 by 2 UHD Scaler with Audio De-Embedded is designed to upscale 1080p signal into 4K2K 6G or downscale 4K2K 6G signal into 1080p with synchronized digital and analog audio output. Friendly and simple design that allow user with direct viewing on input HDMI content and OSD that ease user with output settings/selection. Scaling signal up to 2 simultaneous HDMI output with two different resolutions or generate patterns to output display with assigned resolution allowing on-site display testing. This UHD Scaler is the best define tool between your HD and UHD signal.

Features

- HDMI with 6G 4Kx2K supported and HDCP 2.2 compliant
- Supports HDMI signal bypass on both outputs or upscale 1080p signal into 4K2K on output B and downscale 4K2K signal into 1080p on output A
- Supports 4K2K@50/60 (4:4:4) to 4K2K@50/60(4:2:0) conversion
- Supports auto pattern generation with assigned resolution for on-site display testing
- Supports HDMI input of one 6G and HDMI outputs of two 6G
- Supports HDMI signal bypass, upscale and downscale
- Supports EDID selections
- Supports High-Dynamic-Range (HDR) image
- Supports HDR conversion from 4Kx2K@24/25/30(444/422)10 or 12bit to 4096x2160@24/25/30Hz 8bit fix
- Supports UHD resolutions up to 4Kx2K:
3840x2160@24/25/30Hz, 3840x2160@50/60 Hz (4:4:4) &
4096x2160 @24/25/30 Hz, 4096x2160@50/60Hz (4:4:4)
- Supports data rate up to 6Gbps (600MHz) and Deep Color up to 1080p 48-bit
- Supports pass-through of HD audio formats of LPCM 2/5.1/7.1CH, Dolby Digital 2~5.1CH, DTS 2~5.1CH, Dolby Digital Plus, Dolby TrueHD, Dolby Atmos and DTS-HD Master Audio
- HDMI compatible with DVI
- Supports OSD with instant I/O resolution display
- Supports Digital to Analog (DAC) audio conversion
- Supports Apple mode signal display
- Supports HDCP 2.2 to HDCP1.4 conversion

Note: When displaying HDMI 4Kx2K/HDR signal, equivalent source signal, output display and HDMI cables are required in order to secure the best image display. It is suggested to use Premium High Speed HDMI cable for 6G HDMI signal.

Applications

- On-site equipment testing
- HDMI signal splitting
- Production testing
- R&D design and testing

System Requirements

Input source equipment such as PS3 or Blu-ray player and output display or TV with equivalent HDMI cables.

Operating Functions and Controls

Front Views

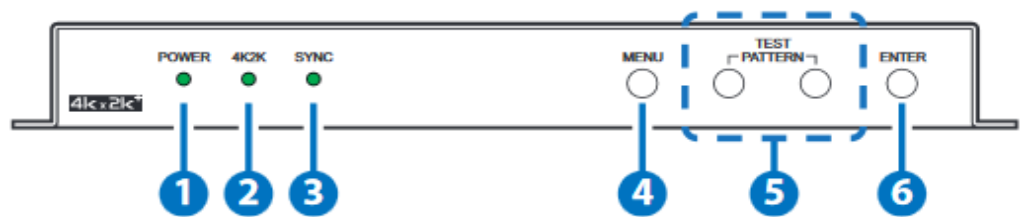

1. POWER LED:

This LED will illuminate when the device is connected with power supply.

2. 4K2K LED:

This LED will illuminate when the input source contains 4K2K signal.

3. SYNC LED:

This LED will illuminate when the input source is sending signal.

4. MENU:

Press this button to enter into OSD menu and when under OSD selection press this button to exit. Press and hold this button together with TEST PATTERN “-“ button for 3 seconds to set the device back to factory default.

5. TEST PATTERN +/-:

Press these buttons to select patterns to display on outputs instantly. Press these buttons together to switch output timing to 1280x720@60 instantly. When under OSD selection, press these buttons to roll the scroll.

6. ENTER:

Press this button to enter and confirm OSD selection.

Press and hold this button together with the MENU button for 3 seconds to enter into firmware update mode. The LEDs will illuminate in circle from left to right. Plug in the USB thumb drive with updated firmware inside and the LEDs will stop illuminating.

Once the update procedure completed or successfully, all LEDs will illuminate together but if update failed no LED will illuminate.

The device will automatically reboot after 10 seconds or user may re-power on the device manually

Rear Views

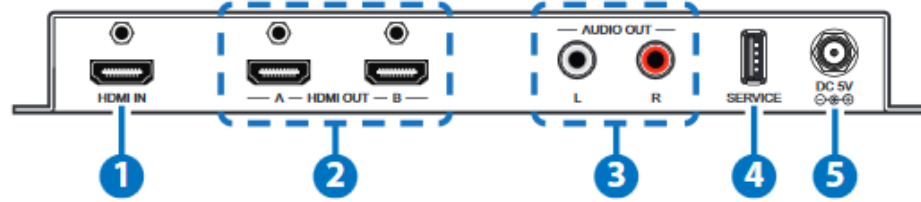

1. HDMI IN:

This slot is to connect with source equipment such as PS3 or Blu-ray player.

2. HDMI OUT:

These slots are to connect with UHD display/TV for images display. Each output can be displaying with different timing and pattern and image.

3. AUDIO OUT L/R:

These slots are to connect with audio equipment such as amplifier or speakers for audio signal output PCM 2CH that is synchronized with HDMI input audio signal.

4. SERVICE:

This slot is reserved for factory firmware update only.

5. DC 5V:

Plug the 5V DC power supply into the unit and connect the adaptor to an AC outlet.

OSD Menu

1 st Level	2 nd Level	3 rd Level	4 th Level
OUTPUT	OUTPUT A	INPUT 4K2K	PASS THROUGH
			DOWN 1080P *1
			FIX 4K2K(420) *2
			FIX 8 BITS *5
	OUTPUT B	INPUT 1080P	PASS THROUGH
			UP 4K2K *3
		INPUT 4K2K	UP 4K2K(420) *4
			PASS THROUGH
		FIX 4K2K(420)	
		FIX 8 BITS *5	
EDID	INT 4K(6G- 2CH)YES/NO	YES/NO	

	INT 4K(3G-2CH)	YES/NO	
	INT 4K(420G-2CH)	YES/NO	
	INT 1080P(2CH)	YES/NO	
	EXT OUT A	YES/NO	
	EXT OUT B	YES/NO	
	EXT OUT A (2CH)	YES/NO	
	EXT OUT B (2CH)	YES/NO	
HDCP	HDCP SUPPORT OFF		
	REFER TO SOURCE		
	REFER TO DISPLAY		
OSD	DISPLAY INFO.	ON	
		OFF	
	OSD TIME OUT	5 SEC.	
		10 SEC.	
		15 SEC.	
		20 SEC.	
		25 SEC.	
		30 SEC.	
		35 SEC.	
40 SEC.			
TEST PATTERN A	MODE	ON	
		OFF	
		AUTO PATTERN	
		AUTO TIMING	
	PATTERN	WHITE COLOR	
	RED COLOR		

		GREEN COLOR	
		BLUE COLOR	
		MEGENTA COLOR	
		YELLOW COLOR	
		CYAN COLOR	
		COLOR BAR	
		RAMP	
		TOGGLE	
	RESOLUTION	720X480P@60	
		720X576P@50	
		1280X720P@50	
		1280X720P@60	
		1920X1080P@50	
		1920X1080P@60	
		3840X2160P@24	
		3840X2160P@25	
		3840X2160P@30	
		4096X2160P@24	
		4096X2160P@25	
		4096X2160P@30	
	HDCP	DISABLE	
		ENABLE	
	SWITCH TIME	10 SEC.	
		20 SEC.	
		30 SEC.	
		40 SEC.	
		50 SEC.	
		1 MIN.	
		2 MIN.	
		3 MIN.	
		5 MIN.	
	AUTO TIMING	720X480P@60	YES/NO

	SELECT	720X576P@50	YES/NO
		1280X720P@50	YES/NO
		1280X720P@60	YES/NO
		1920X1080P@50	YES/NO
		1920X1080P@60	YES/NO
		NEXT PAGE	
		3840X2160P@24	YES/NO
		3840X2160P@25	YES/NO
		3840X2160P@30	YES/NO
		4096X2160P@24	YES/NO
		4096X2160P@25	YES/NO
		4096X2160P@30	YES/NO
		PREVIOUS PAGE	
		TEST PATTERN B	MODE
ON			
AUTO PATTERN			
AUTO TIMING			
PATTERN	WHITE COLOR		
	RED COLOR		
	GREEN COLOR		
	BLUE COLOR		
	MEGENTA COLOR		
	YELLOW COLOR		
	CYAN COLOR		
	COLOR BAR		
	RAMP		
	TOGGLE		
RESOLUTION	720X480P@60		
	720X576P@50		
	1280X720P@50		
	1280X720P@60		
	1920X1080P@50		

		1920X1080P@60		
		3840X2160P@24		
		3840X2160P@25		
		3840X2160P@30		
		4096X2160P@24		
		4096X2160P@25		
		4096X2160P@30		
	SWITCH TIME	10 SEC.		
		20 SEC.		
		30 SEC.		
		40 SEC.		
		50 SEC.		
		1 MIN.		
		2 MIN.		
		3 MIN.		
	HDCP	DISABLE		
		ENABLE		
	AUTO TIMING SELECT	720X480P@60	YES/NO	
		720X576P@50	YES/NO	
		1280X720P@50	YES/NO	
		1280X720P@60	YES/NO	
		1920X1080P@50	YES/NO	
		1920X1080P@60	YES/NO	
		NEXT PAGE		
		3840X2160P@24	YES/NO	
		3840X2160P@25	YES/NO	
		3840X2160P@30	YES/NO	
		4096X2160P@24	YES/NO	
		4096X2160P@25	YES/NO	
		4096X2160P@30	YES/NO	
		3840X2160P@50	YES/NO	
	3840X2160P@60	YES/NO		

		4096X2160P@50	YES/NO
		4096X2160P@60	YES/NO
		PREVIOUS PAGE	
INFORMATION	RESOLUTION	INPUT	XXX
		OUTPUT A	XXX
		OUTPUT B	XXX
	HDCP	OUTPUT A	DISABLE/ENABLE
		OUTPUT B	DISABLE/ENABLE
	FIRMWARE	VERSION	VX.XX
FIRMWARE UPDATE	NO		
	YES		
FACTORY SETTING	NO		
	YES		

Default settings are in bold font

Note:

When input timing is non-VESA standard, OSD may be disable.

To enter into OSD selection, press hot keys to enter into test pattern mode and do the OSD selection

* 1 Input → Output

3840x2160@24 → 1920x1080p@24
3840x2160@25 → 1920x1080p@25
3840x2160@30 → 1920x1080p@30
3840x2160@50 → 1920x1080p@50
3840x2160@60 → 1920x1080p@60
4096x2160@24 → 1920x1080p@24
4096x2160@25 → 1920x1080p@25
4096x2160@30 → 1920x1080p@30
4096x2160@50 → 1920x1080p@50
4096x2160@60 → 1920x1080p@60

* 2 Input → Output

3840x2160@50(RGB,YCbCr444,Ycbcr422) →
3840x2160@50(YCbCr420)
3840x2160@60(RGB,YCbCr444,Ycbcr422) →
3840x2160@60(YCbCr420)
4096x2160@50(RGB,YCbCr444,Ycbcr422) →
4096x2160@50(YCbCr420)
4096x2160@60(RGB,YCbCr444,Ycbcr422) →
4096x2160@60(YCbCr420)

- * 3 Input → Output
 - 1920x1080p@24 → 3840x2160@24
 - 1920x1080p@25 → 3840x2160@25
 - 1920x1080p@30 → 3840x2160@30
 - 1920x1080p@50 → 3840x2160@50
 - 1920x1080p@60 → 3840x2160@60

- * 4 Input → Output
 - 1920x1080p@50(RGB, YCbCr444, Ycbcr422) → 3840x2160@50(YCbCr420)
 - 1920x1080p@60(RGB, YCbCr444, Ycbcr422) → 3840x2160@60(YCbCr420)

- * 5 Input → Output
 - 4K2K@24/25/30(RGB, YCbCr444, YCbCr422) 10/12/16bit → 4K2K@24/25/30(RGB, Ycbcr444, Ycbcr422) 8bit
 - 4K2K@50/60(YCbCr420) 10/12/16bit → 4K2K@50/60(YCbCr420) 8bit

Connection Diagram

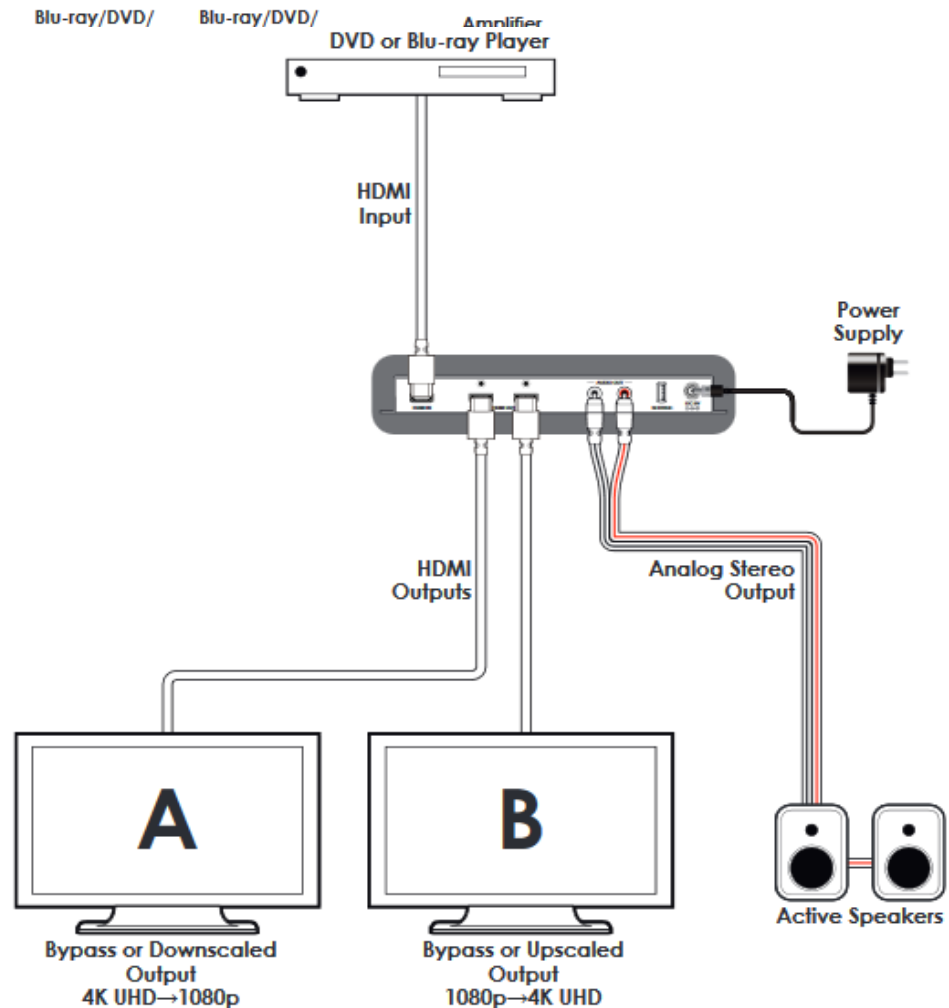

Specifications

VideoBandwidth	600MHz/18G 1 x USB (Service only)
Output ports	2 x HDMI 1 x R/L
HDMI Cable Length	15 m@1080p/8-bit, 10 m@1080p/12-bit, 5 m@4K
Power Supply	5V DC/2.6A (US/EU standards, CE/FCC/UL certified)
ESD Protection	Human body model: ±8kV (air-gap discharge) ±4kV (contact discharge)
Dimensions	231.5mm (W) x 117mm (D) x 25mm (H)
Weight	616g
Chassis Material	Metal
Silkscreen Color	Black
Operating Temperature	0°C~40°C / 32°F ~ 104°F
Storage Temperature	-20°C~60°C / -4°F ~ 140°F
Relative Humidity	20~90% RH (no condensation)
Power Consumption	5.8W

Note:

HDMI cable distance might affected by material or design of cable. It is suggested to use Premium High Speed HDMI cable for 6G HDMI signal.

DVI and HDMI Supported Resolutions	Input	Output
640x480i@60	Y	Y
640x480p@72	Y	Y
720x480i@60	Y	Y
720x576p@50	Y	Y
800x600@60	Y	Y
800x600@56/60/72/75/85	Y	Y
1024x768@60/70/75/85	Y	Y
1280x720p@50/60	Y	Y
1280x768@60 /75	Y	Y
1280x800@60 /75	Y	Y
1280x1024@60 /75	Y	Y
1366x768@60	Y	Y
1400x1050@60/75	Y	Y
1440x900@60/75	Y	Y
1600x900@60	Y	Y
1600x1200@60	Y	Y
1680x1050@60	Y	Y
1920x1080i@50/60	Y	Y
1920x1080p@24/25/30/50/60	Y	Y
1920x1200@60	Y	Y
3840x2160@24/25/30/50/60	Y	Y
4096x2160@24/25/30/50/60	Y	Y

Input Level/ Freq	Output Terminal	Output Level	THD+N	Frequency Response	SNR	Crosstalk
HDMI 0dBFS 20 、 1K 、 20KHz	HDMI	0dB~-1dB	<0.01%	±1dB	>80dB	<-80dB
	L/R	Vrms±10 %	<0.1%	±3dB	>70dB	<-60dB